

# 6" HYDRAULIC SUBMERSIBLE AXIAL FLOW HIGH VOLUME PUMP

## MODEL

**S6P**

**6" (150 mm) Discharge**

The S6P is a lightweight axial flow pump designed for pumping high volumes of water at relatively low heads. The propeller design allows this pump to be driven by small hydraulic power sources such as small tractors, backhoes or our 10 to 13 HP power units. This pump is great for lake draining, tank filling, flood irrigation, aerial firefighting and cofferdam dewatering. Flows to 1100 GPM! Use auxiliary power from a tractor to flood duck blinds quickly.



## FEATURES

- High Volume Axial Propeller design
- Very Light Weight allows for one person set-up
- Small Overall Size for use in very tight spaces
- Variable Speed hydraulic drive
- Oil Lubricated Seals (can run dry)
- Dependable gear type hydraulic motor
- Safe Hydraulic Drive can be used where electric power is hazardous or impractical
- Operates with our HT10 to HT13 power units or other hydraulic power sources capable of flows of 5 - 7 GPM

## SPECIFICATIONS

WEIGHT:.....	40 lbs. (18 kg)
HEIGHT:.....	16" (41 cm)
DIAMETER (@ widest point):.....	11 3/4" (30 cm)
DISCHARGE:.....	6" NPT(F)
SOLIDS HANDLING:.....	3/4" (2 cm)
HOSE PORTS:.....	1/2" NPT
PUMP BODY:.....	Heat Treated Aluminum
PROPELLER:.....	Ductile Iron
WEAR RING.....	Ductile Iron
SHAFT:.....	Plated Steel
SHAFT SEAL:.....	Carbon/Ceramic (Std)
ELASTOMERS:.....	Buna N (Std)
HYDRAULIC OIL:.....	214-320 s.s.u. @ 100°F (64°C)
INPUT FLOW:.....	Max. 7 GPM (26 LPM)
INPUT PRESSURE:.....	Max. Cont. 2500 PSI (170 Bar)
POWER SOURCE:....	Any Open Center Hydraulic System

D0516

Specifications are subject to change without notice

## Model S6P Overall Dimensions

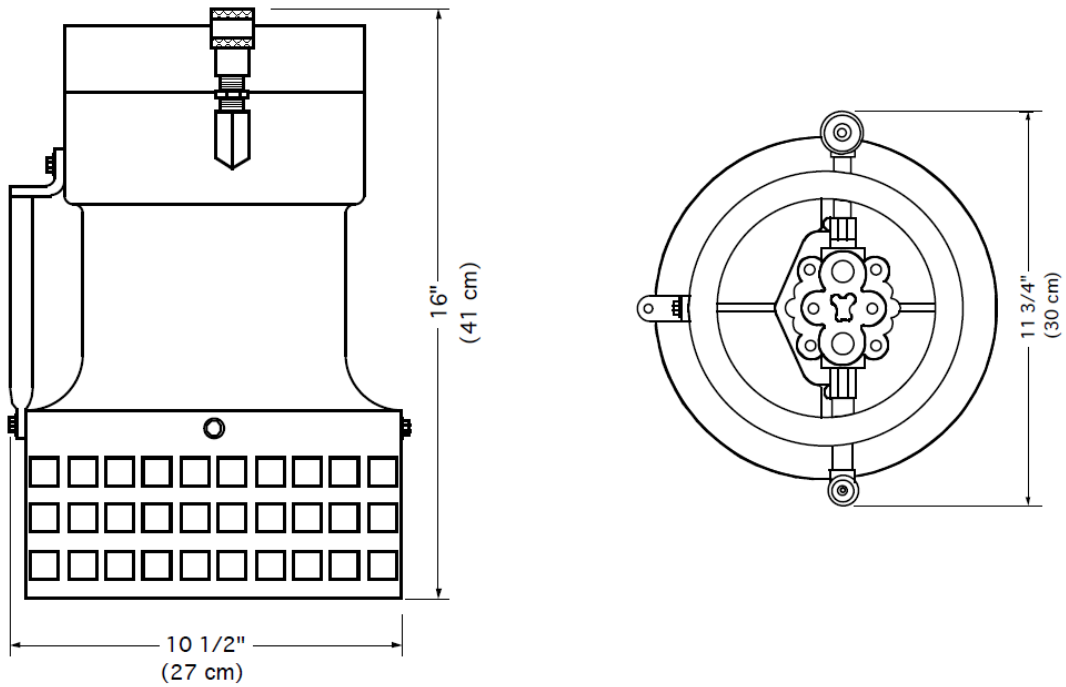

## S6P Typical Performance

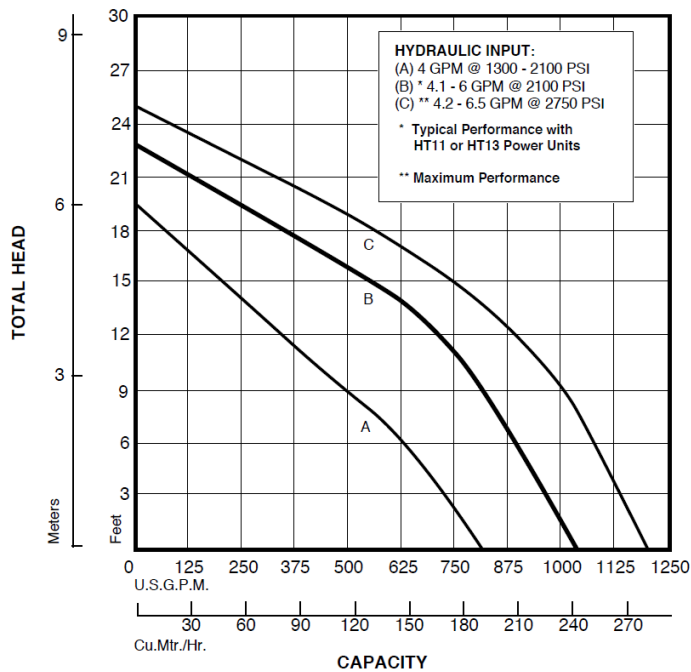

Curves are based on pumping water at 60°F. For performance curves other than shown above, consult factory.