

10" HYDRAULIC SUBMERSIBLE VORTEX FLOW TRASH PUMP

MODELS

S10T

10" (250 mm) Discharge

The S10T is designed to handle large solids and stringy material with its fully recessed Vortex impeller. Typical applications include sludge lagoons, sewage digester tanks and fish farms.



FEATURES

- Recessed Vortex Impeller (will pass 8" semi-solids)
- Variable Speed hydraulic drive provides a wide range of performance
- Oil Lubricated Seals (can run dry)
- High Efficiency Balanced Vane hydraulic motor
- Can be bolted directly into a pipeline or used as a booster pump
- Safe Hydraulic Drive can be used where electric power is hazardous or impractical
- Operates with our HT100 to HT150 power units or other hydraulic power sources capable of flows of 50 - 70 GPM

SPECIFICATIONS

WEIGHT:	745 lbs. (346 kg)
HEIGHT:	45" (114 cm)
WIDTH (@ widest point):	42 1/2" (108 cm)
DISCHARGE:	10" 125# ASA Flange
INLET:	10" 125# ASA Flange
SOLIDS HANDLING: (spherical semi-solids):	8" (20 cm)
HOSE PORTS:	1 1/4" or 1 1/2" NPT(F) or SAE
PUMP BODY:	Ductile Iron
IMPELLER:	Ductile Iron
WEAR RING and PLATE:	ASTM A36 Steel
SHAFT:	17-4 PH Stainless Steel
SHAFT SEAL:	Silicon Carbide
ELASTOMERS:	Buna N (Std)
HYDRAULIC OIL:	214-320 s.s.u. @ 100°F (64°C)
INPUT FLOW:	Max 70 GPM (265 LPM)
OPERATING PRESSURE:	Max 2800 PSI (190 Bar)
POWER SOURCE:	Any Open Center Hydraulic System

D0516

Specifications are subject to change without notice

Model S10T Overall Dimensions

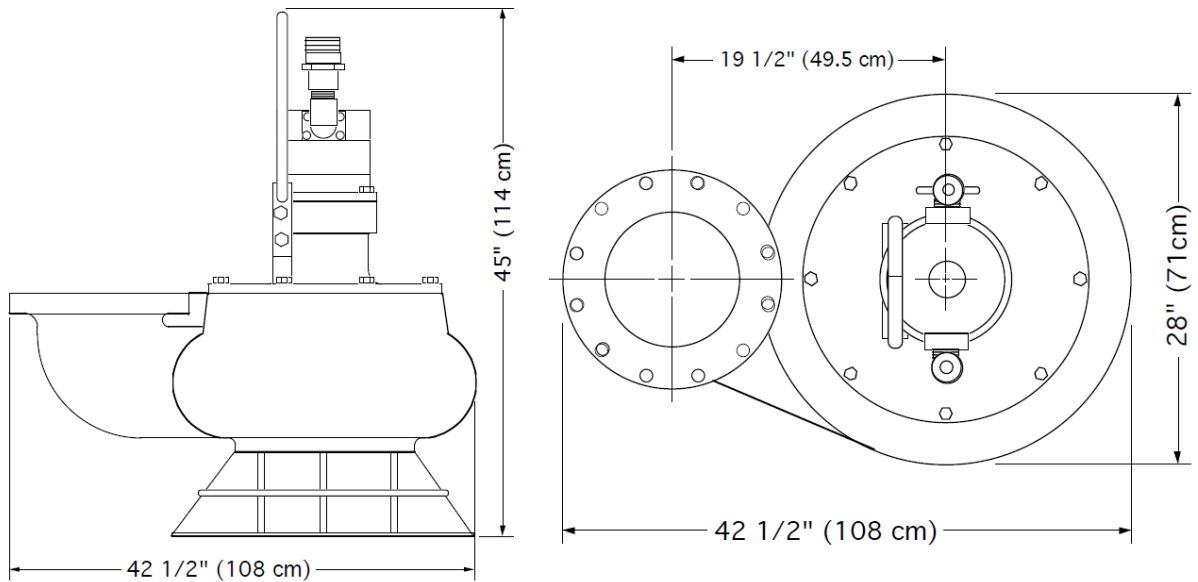

S10T Typical Performance

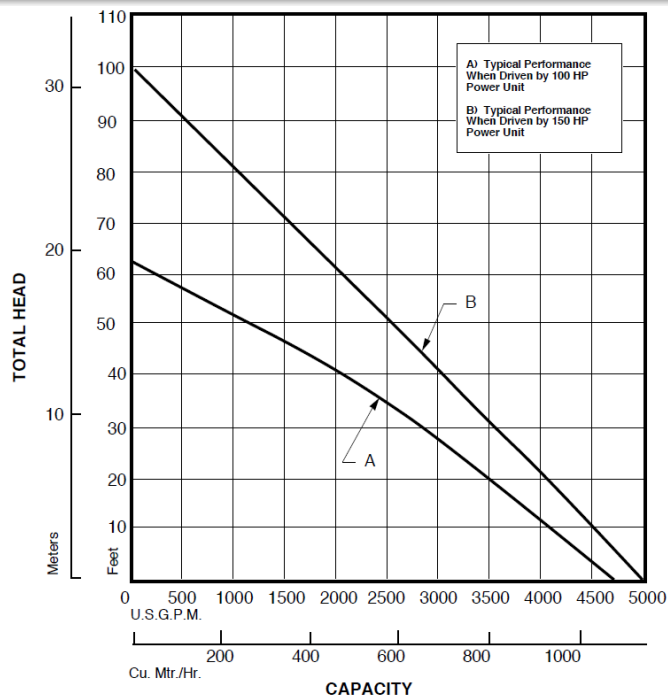

Curves are based on pumping water at 60°F. For performance curves other than shown above, consult factory.